

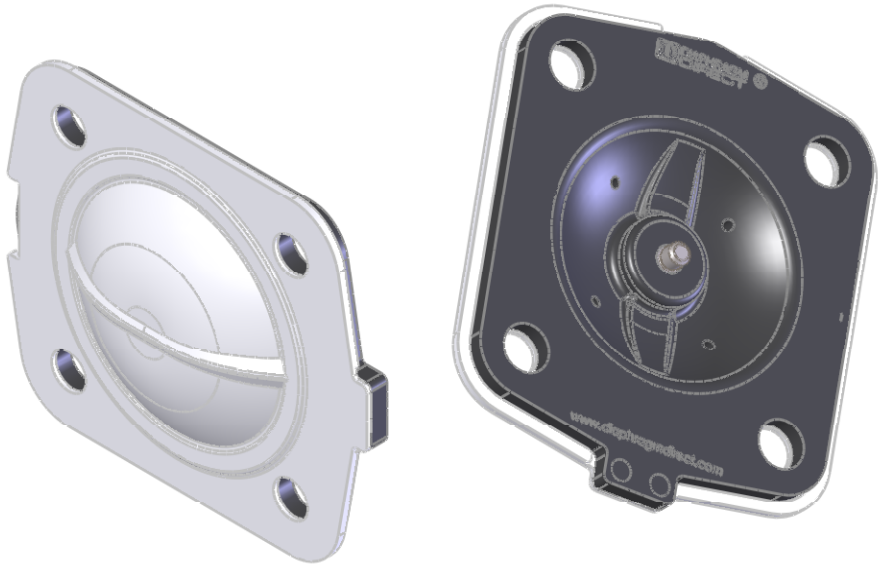

Revision History

Rev	Description	Date	Approved
A	New Drawing & OEM No.	26/09/24	JB

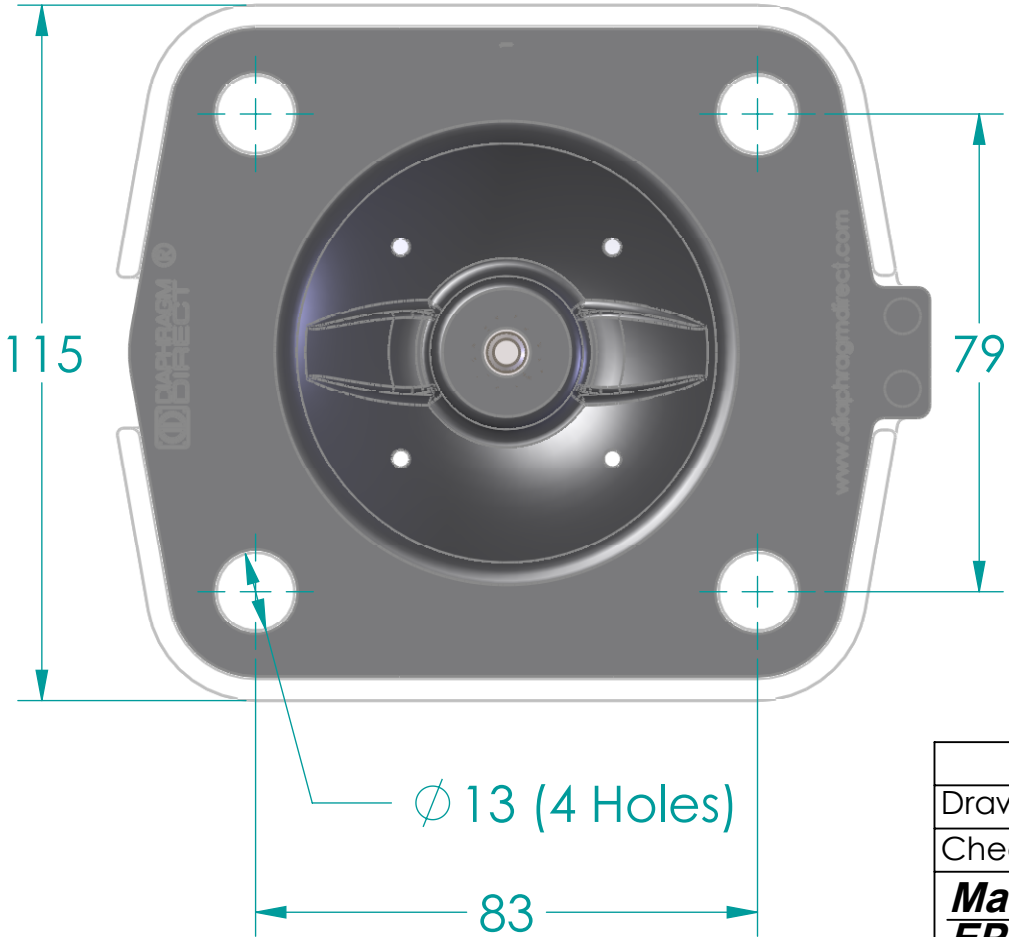
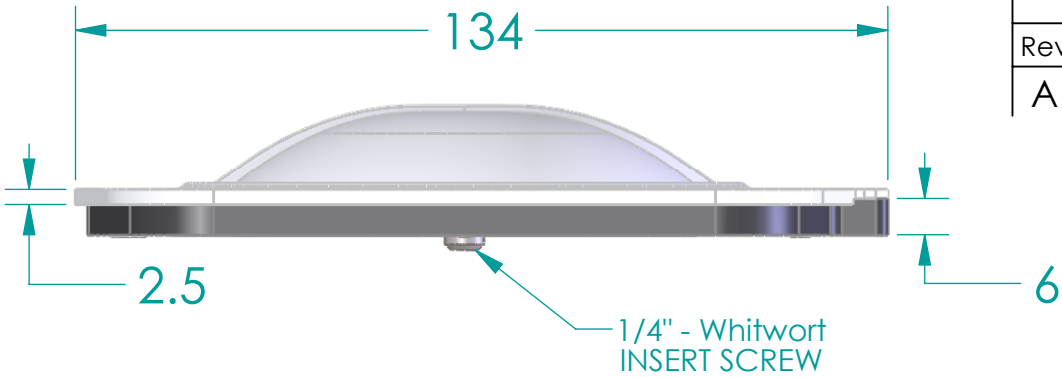

Replacement Diaphragm for:-
OEM PART NUMBER = 600 50M5M
USED ON 2"(DN50) Diaphragm Valve

	Name	Date	 DIAPHRAGM DIRECT
Drawn	M.Mc Keon	28/09/24	
Checked			
Material - EPDM BACKING PTFE-DIAPHRAGM Complies with CFR 177.2600 and Conforms to USP Class VI Biological Reactivity Tests Section #87 and #88			TITLE DD20-GTFM-M Size A FOOT PRINT DIMENSIONS Rev A File: DD20-GTFM-M SCALE: 1:1.25 mm Sheet 1 of 1

Disclaimer - Diaphragm Direct® does not manufacture, represent, nor sell OEM valves or diaphragms manufactured by any other company. Diaphragm Direct® brand diaphragms are not sponsored by any other manufacturers. Any name, model, part number, brand, image, material or referral is for descriptive purposes only. Diaphragm Direct® brand replacement diaphragms are guaranteed to fit OEM equipment and meet or exceed OEM specifications. Diaphragm Direct® brand replacement diaphragms are covered by the standard Diaphragm Direct® limited product warranty.